

**ESPLOSO E LISTA RICAMBI**

**fondital**

**NIAS DUAL  
BTFS 24-28-32**

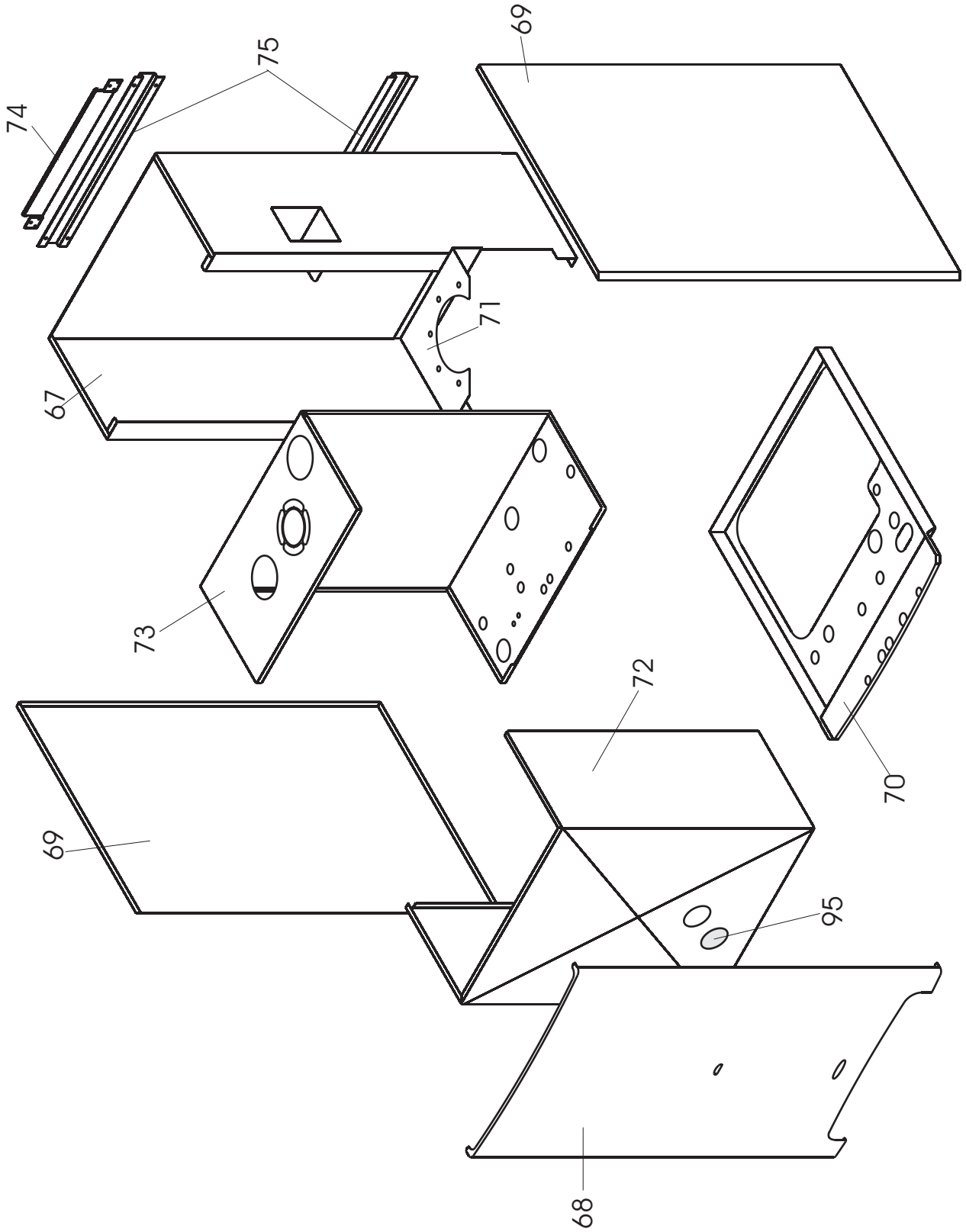



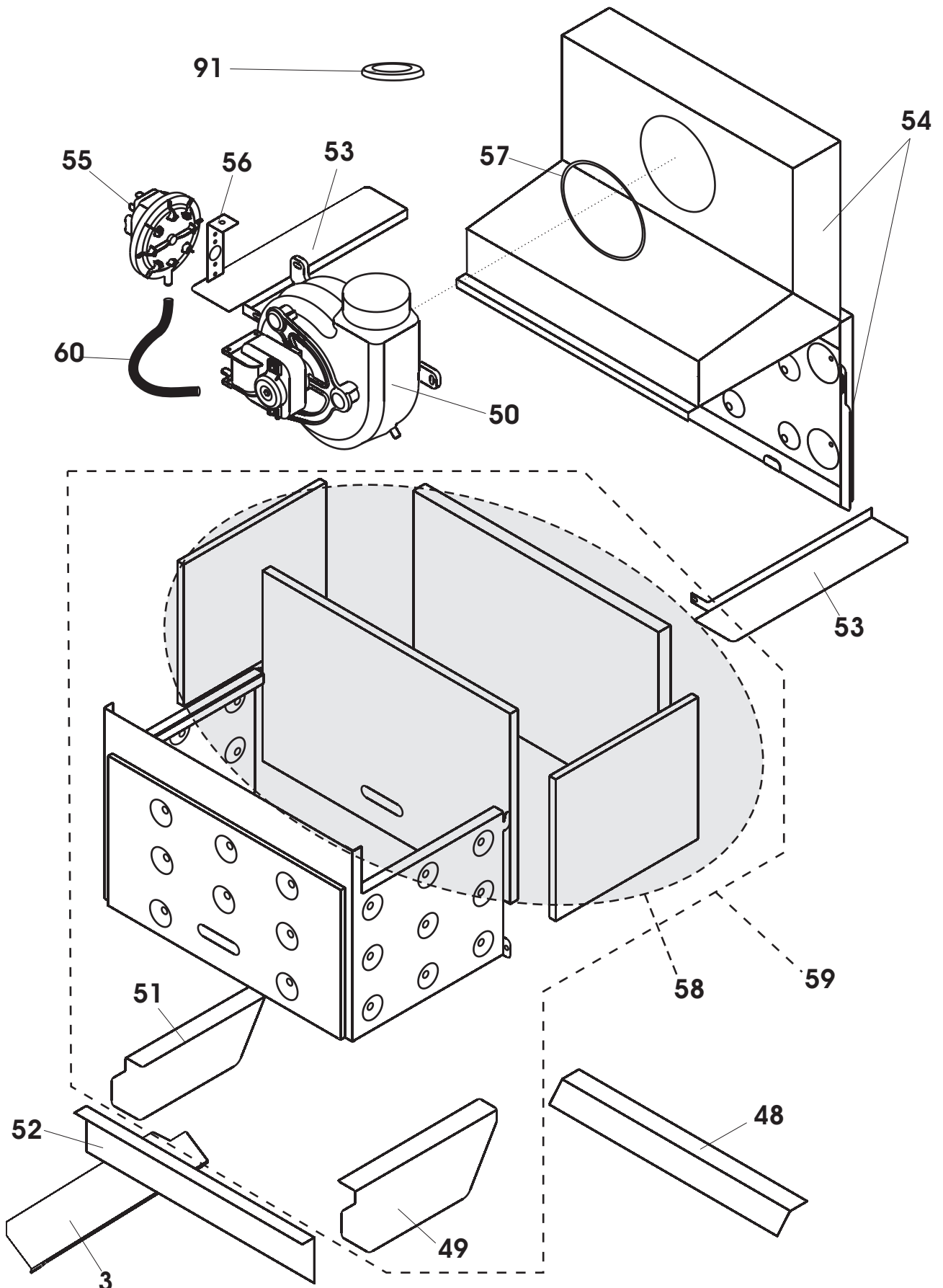

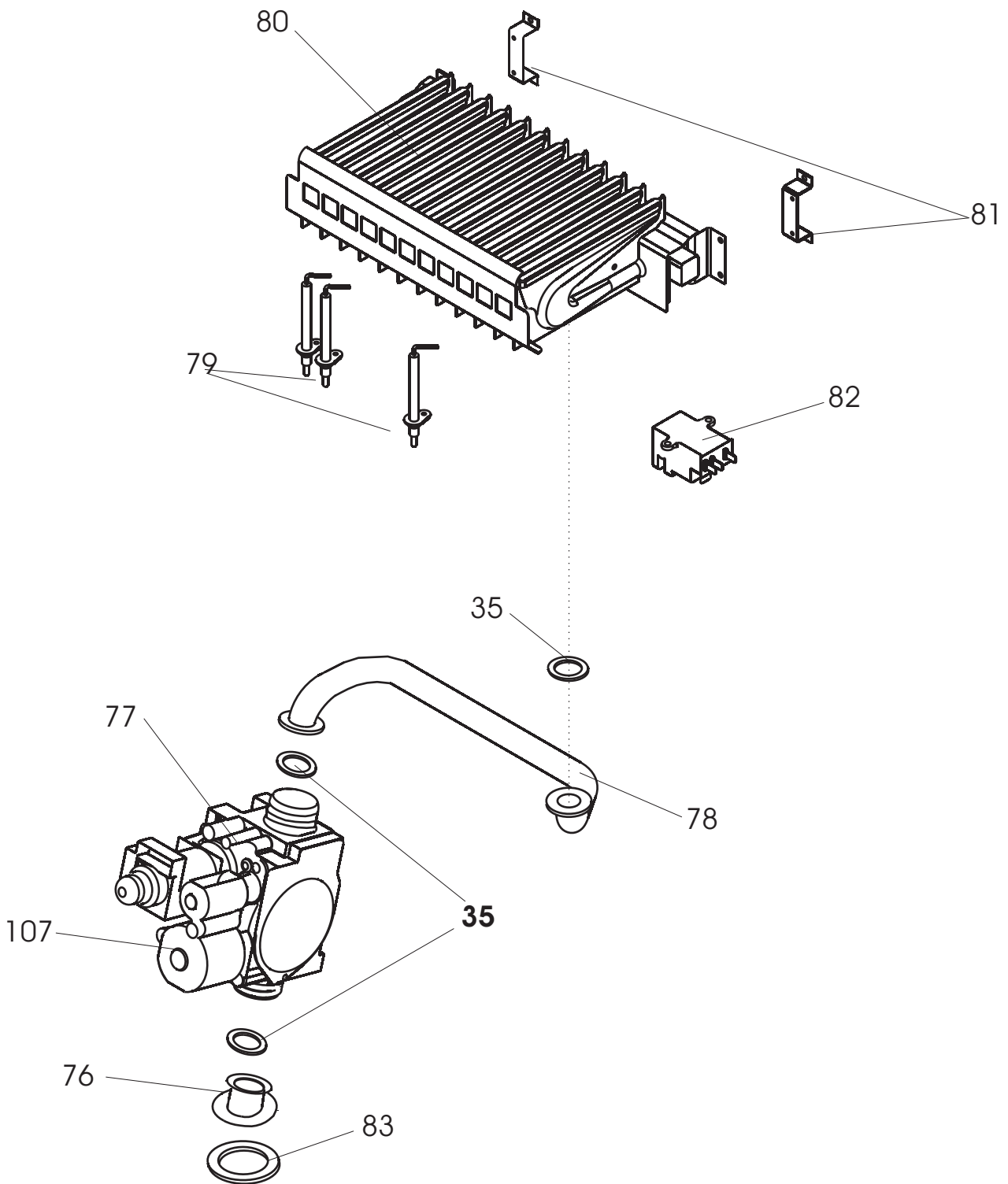

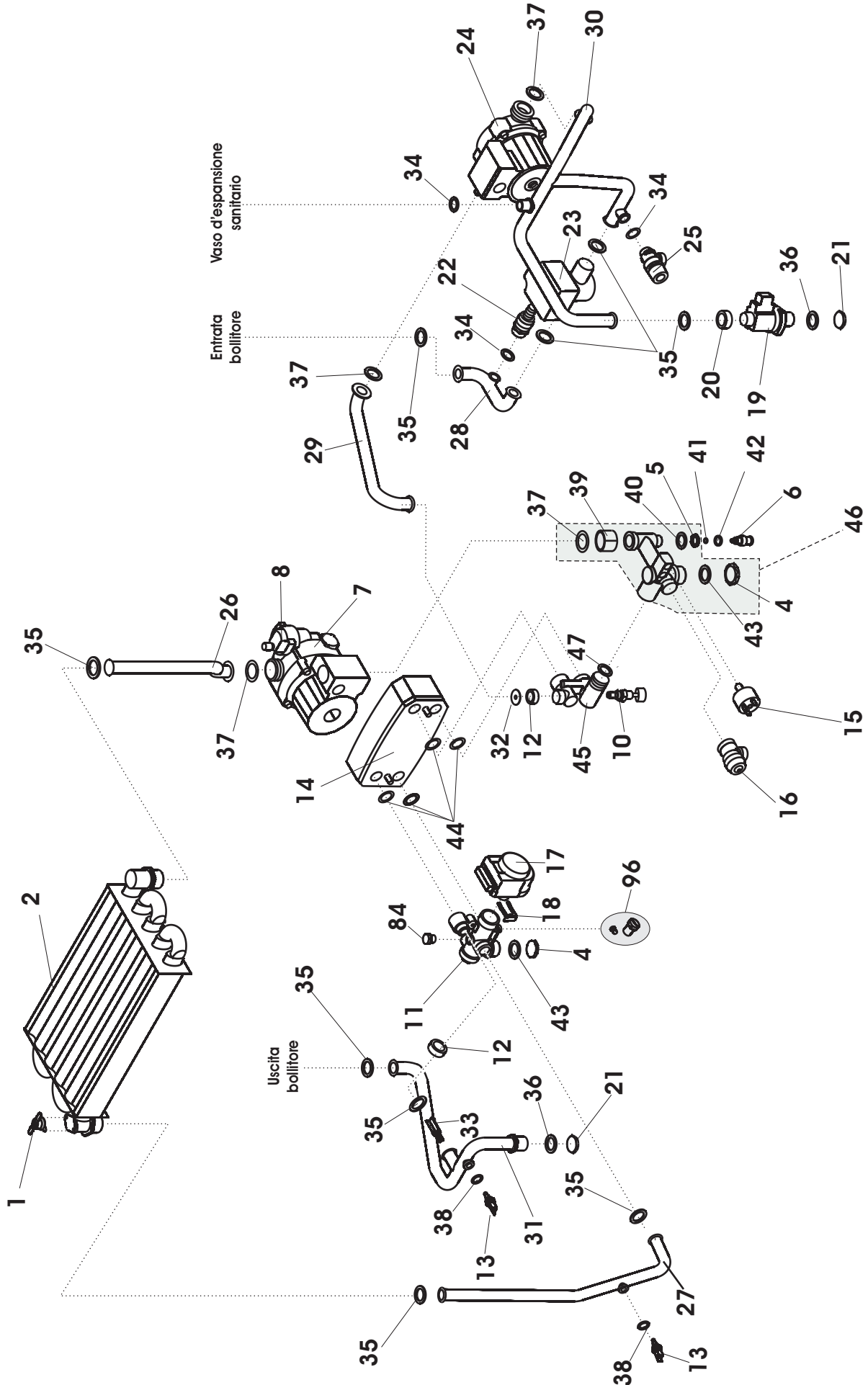

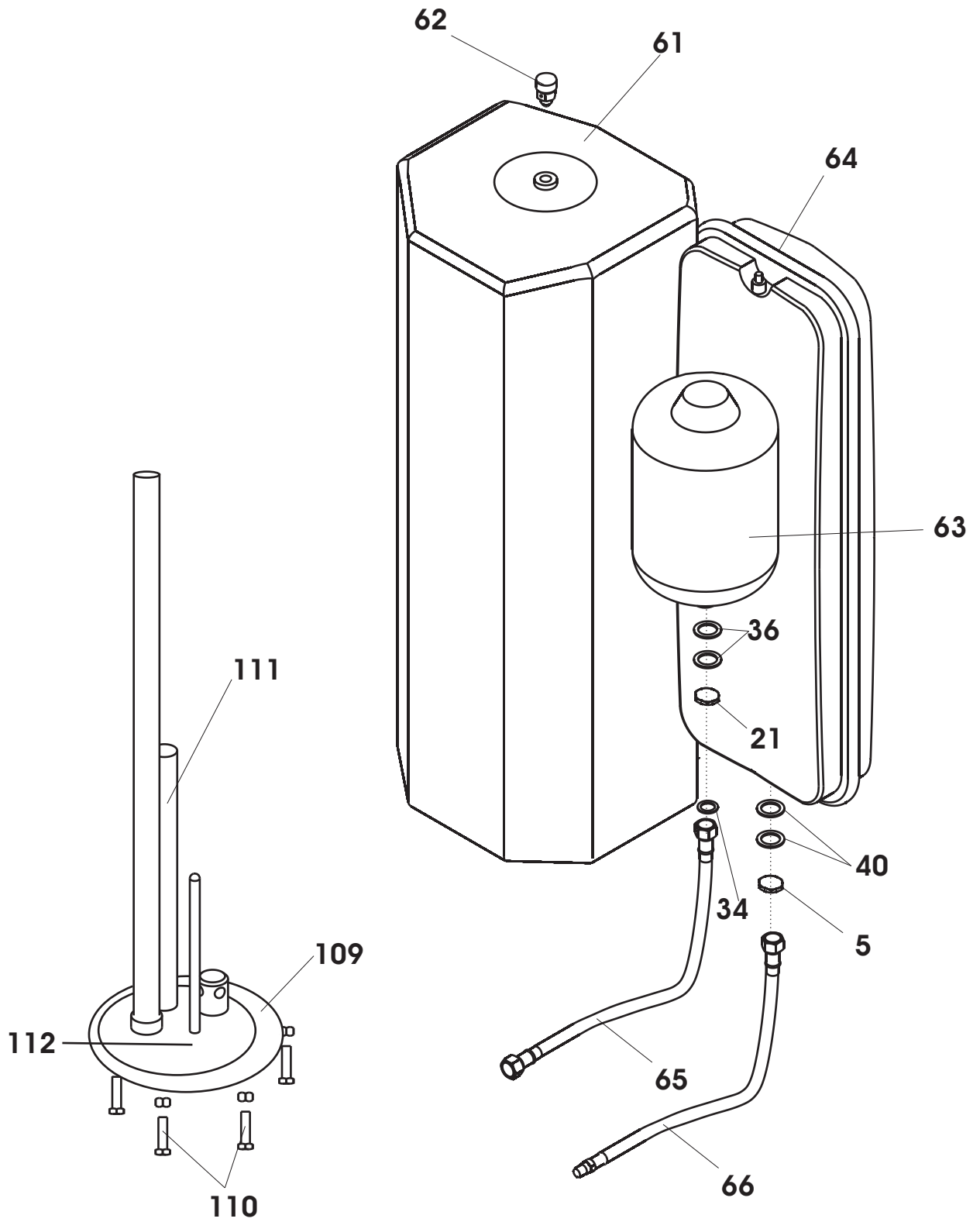

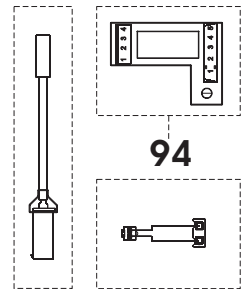
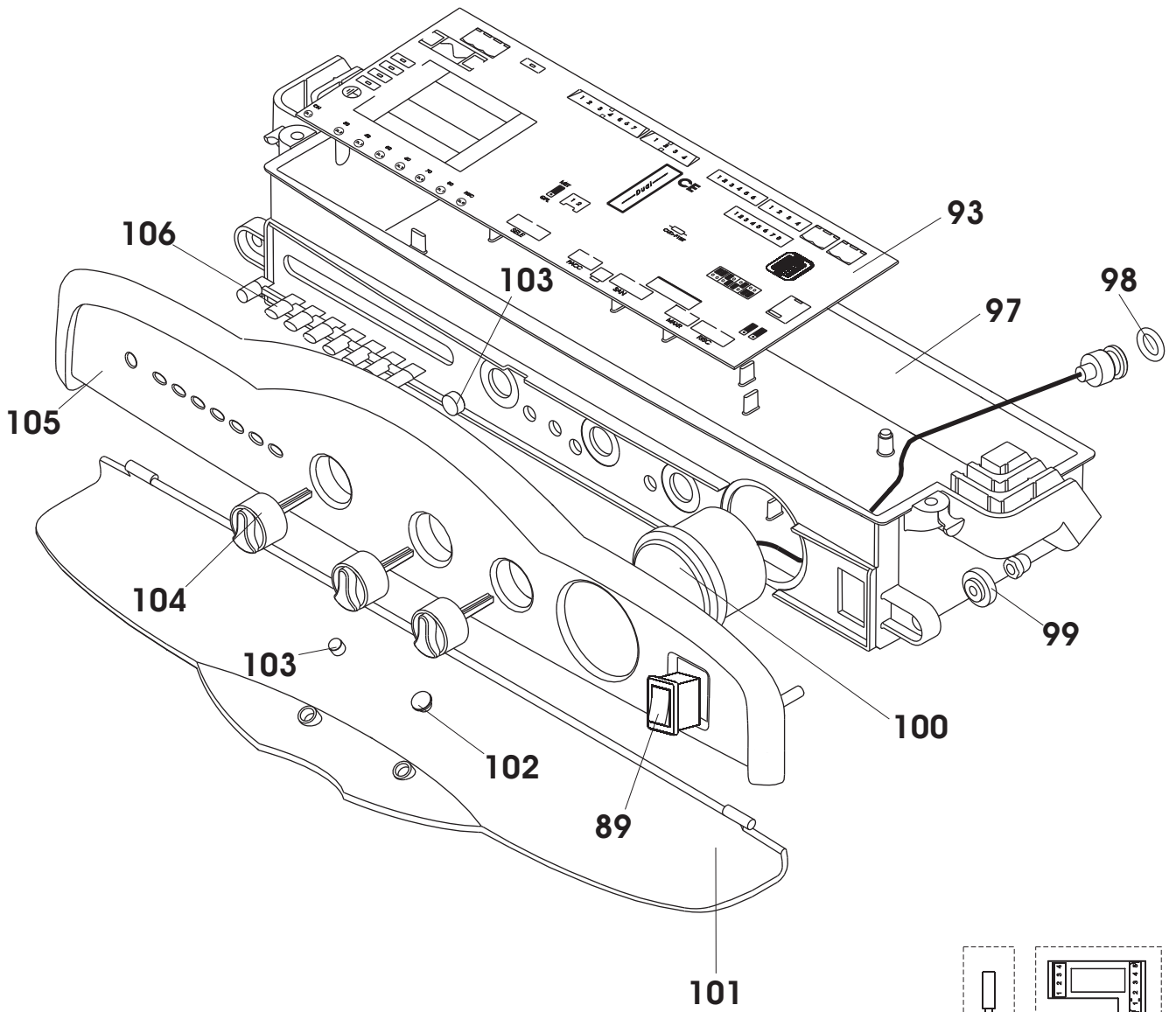

88

108

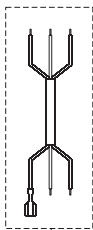

85

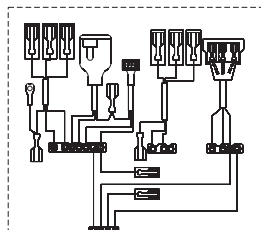

86

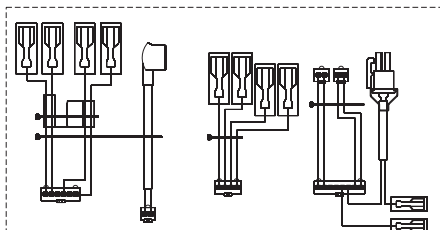

87

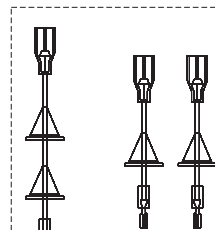

90

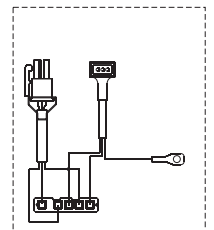

92

### Riferimenti esploso NIAS Dual BTFS 24-28-32

Esp	Codice	Pezzi	Descrizione	Description
1	6YTER SIC00	3	TERMOSTATO DI SICUREZZA 105 °C	SAFETY THERMOSTAT 105 °C
2	6SCAMMON05	1	SCAMBIATORE VALMEX MONOTERMICO 5 TUBI (24 KW)	VALMEX 5-DUCT EXCHANGER (24 KW)
	6SCAMPRI00	1	SCAMBIATORE PRIMARIO 5 TUBI OVALE (28-32 KW)	MAIN HEAT EXCHANGER - 5 OVAL PIPES (28-32 KW)
3	6DEFLINF00	1	DEFLETTORE INFERIORE CALDAIA 32KW	UNDER SIDE DEFLECTOR 32KW
4	6GHIEROT01	3	GHIERA ¾"	RING NUT G3/4"
5	6Y41138700	3	DADO DI FISSAGGIO PORTA-UGELLO PER BRUCIATORE	BURNER NOZZLE SECURING NUT
6	6RUBISCA01	1	CORPO RUBINETTO DI SCARICO PER CALDAIA	BOILER DRAIN COCK UNIT
7	6CIRCOLA07	1	CIRCOLATORE RSL 15/6-3-KU-CLR-3 (24-28 KW)	CIRCULATING PUMP RSL 15/6-3-KU-CLR-3 (24-28 KW)
	6CIRCOLA10	1	CIRCOLATORE RSL 15/7-3-KU-CLR-3 (32 KW)	CIRCULATING PUMP RSL 15/7-3-KU-CLR-3 (32 KW)
8	6DEGASAT00	1	DEGASATORE PER CALDAIE MURALI	DEGASSER FOR WALL-HUNG BOILERS
10	6RUBICAR04	1	RUBINETTO DI RIEMPIMENTO KRAMER L=50	KRAMER L=50 FILLING TAP
11	6CORPVAL01	1	CORPO VALVOLA A 3 VIE MOTORIZZATA	3-WAY MOTORIZED VALVE BODY
12	6RIDUZIO04	1	RIDUZIONE G3/4 M-G1/2 F	ADAPTER G3/4 M-G1/2 F
13	6SONDN TC01	3	SONDA NTC AD IMMERSIONE DUAL	NTC IMMERSION PROBE
14	6SCAMP IA05	1	SCAMBIATORE A 22 PIASTRE	22 PLATE HEAT EXCHANGER
	6SCAMP IA06	1	SCAMBIATORE A 26 PIASTRE	26 PLATE HEAT EXCHANGER
15	6PRESSAC00	1	PRESSOSTATO ACQUA	NO WATER PRESSURE SWITCH
16	6VALSIBA07	1	VALVOLA SICUREZZA 3 BAR INNESTO RAPIDO	3 BAR SNAP-ON SAFETY VALVE
17	6PROATT T00	1	PROGRAMMATORE ATTUATORE 1651/2.0.00	ACTUATOR PROGRAMMER 1651/2.0.00
18	6CLIFMEL00	3	CLIP FISSAGGIO MOTORE ELETTRICO	ELECTRIC MOTOR FIXING CLIP
19	6FLUSSOS00	1	FLUSSOSTATO BITRON	"BITRON" FLOW CONTROL
20	6RIDUZIO06	1	RIDUZIONE G1/2"F G3/4"M	ADAPTER G1/2"F G3/4"M
21	6GHIEROT00	3	GHIERA ½"	½" G RING NUT
22	6RUBISCA04	1	RUBINETTO DI SCARICO 1/2"	DRAIN COCK 1/2"
23	6VALVINT00	1	VALVOLA 2 VIE	2 WAY VALVE
24	6CIRCOLA09	1	CIRCOLATORE ZRS 15-2-1 KU	CIRCULATING PUMP ZRS 15-2-1 KU
25	6VALSIBA08	1	VALVOLA SICUREZZA 6BAR 1/2"	6 BAR SAFETY VALVE 1/2"
26	6TUBRIIM07	1	TUBO RITORNO IMPIANTO RISCALDAMENTO	RETURN DUCT FROM THE HEATING SYSTEM
27	6TUBMAIM11	1	TUBO DI MANDATA IMPIANTO RISCALDAMENTO	DELIVERY PIPE TO SYSTEM
28	6TUBACFR06	1	TUBO ACQUA FREDDA BOLLITORE	BOILER COLD WATER TUBE
29	6TUBACFR04	1	TUBO ACQUA FREDDA POMPA-SCAMBIATORE	CIRC. PUMP-HEAT EXCHANGER COLD WATER TUBE
30	6TUBACFR05	1	TUBO CARICO ACQUA FREDDA SANITARIA	WATER MAIN INLET PIPE
31	6TUBUSCS05	1	TUBO USCITA ACQUA CALDA SANITARIA	DHW FLOW PIPE
32	6DIAFRAM15	5	DIAFRAMMA CALDAIA MURALE 24KW 5.8MM	DIAPHRAGM 24KW 5.8MM
	6DIAFRAM16	5	DIAFRAMMA CALDAIA MURALE 28KW 6.0MM	DIAPHRAGM 28KW 6.0MM
	6DIAFRAM17	5	DIAFRAMMA CALDAIA MURALE 32KW 6.7MM	DIAPHRAGM 32KW 6.7MM
33	6TURBOLA01	1	TURBOLATORE ACQUA SANITARIA	COLD WATER SANITARIE FLUE TURBULENCE ENHANCER
34	6GUARNIZ04	10	GUARNIZIONE 18X12	GASKET 18X12
35	6GUARNIZ05	10	GUARNIZIONE 24X17	GASKET 24X17
36	6GUARNIZ25	10	GUARNIZIONE 33X21X1,5	GASKET 33X21X1,5
37	6GUARNIZ07	10	GUARNIZIONE 30X21	GASKET 30X21
38	6WRONDAL00	10	RONDELLA IN ALLUMINIO PER UGELLO	ALUMINIUM WASHER FOR NOZZLE
39	6GIRELLO03	3	GIRELLO G 1" PER RACCORDO POMPA	1" G PUMP FITTING COLLAR
40	6GUARNIZ27	10	GUARNIZIONE 27X17X1,5	GASKET 27X17X1,5



41	6ORRUBSC01	10	O-RING DI CHIUSURA RUBINETTO DI SCARICO	DRAIN TAP CLOSING O-RING
42	6ORRUBSC00	10	O-RING DI TENUTA SU RUBINETTO DI SCARICO	DRAIN COCK O-RING SEAL
43	6GUARNIZ26	10	GUARNIZIONE 37X26,5X1,5	GASKET 37X26,5X1,5
44	6ORSCAPI00	10	O-RING DI TENUTA SU SCAMBIATORE A PIASTRE	PLATE HEAT EXCHANGER O-RING SEAL
45	6GRURIRC00	1	GRUPPO RICAMBIO RUBINETTO DI CARICO	SPARE FILLING TAP UNIT
46	6GRIDRIR01	1	GRUPPO IDRAULICO RICAMBIO DI RITORNO RISC.	HYDRAULIC UNIT FOR HEATING RETURN CIRCUIT
47	6ORRASCP00	10	O-RING DI TENUTA SU RACCORDO PER SCAMBIATORE	HEAT EXCHANGER O-RING SEAL
48	6DEFLEPOS00	1	DEFLETTORE POS. PER CAPP A FUMI DUAL 28	POSTERIOR DEFLECTOR FOR DUAL 28
	6DEFLEPOS01	1	DEFLETTORE POSTERIORE CALDAIA 32KW	POSTERIOR DEFLECTOR 32KW
49	6DEFLEDX00	1	DEFLETTORE DESTRO CAPP A FUMI CALDAIA 24-28 KW	RIGHT DEFL.FOR WALL-HUNG BOIL.FLUE GAS HOOD
	6DEFLEDX01	1	DEFLETTORE DESTRO PER CALDAIA 32KW	DX DEFLECTOR 32KW
	6VENTILA07	1	VENTILATORE FIME 24KW	24 KW FAN
50	6VENTILA10	1	VENTILATORE 28KW	28 KW FAN
	6VENTILA09	1	VENTILATORE 32KW	32 KW FAN
51	6DEFLESX00	1	DEFLETTORE SINISTRO CAPP A FUMI CALDAIA 24-28 KW	LEFT DEFL.FOR WALL-HUNG BOIL. FLUE GAS HOOD
	6DEFLESX01	1	DEFLETTORE SINISTRO CALDAIA 32KW	SX DEFLECTOR 32KW
52	6DEFLANT00	1	DEFLETTORE ANT. PER CAPP A FUMI DUAL 28	FRONTAL DEFLECTOR FOR DUAL 28
	6DEFLANT02	1	DEFLETTORE ANTERIORE CALDAIA 32KW	FRONT SIDE DEFLECTOR 32KW
53	6ALETTC00	1	ALETTA LATERALE PER CAPP A FUMI	SIDE WING FOR FLUE GAS HOOD
54	6CAPFURC00	1	CAPP A FUMI RICAMBIO COMPATTA	FLUE GAS HOOD FOR WALL-HUNG BOILERS
55	6YPRESSO00	1	PRESSOSTATO ARIA 42/52 PA 24 KW	AIR PRESSURE SWITCH 42/52 PA 24 KW
	6PRESSOS02	1	PRESSOSTATO ARIA 67/57 PA 28-32 KW	AIR PRESSURE SWITCH 67/57 PA 28-32KW
56	6YSTATER00	1	STAFFA DI SUPPORTO TERM.SIC.	SUPPORTING BRACKET FOR SAFETY THERMOSTAT
57	6ORVENCA00	10	O-RING DI TENUTA VENTILATORE CENTRIFUGO	CENTRIFUGAL FAN O-RING SEAL
58	6SETISRC00	1	SET DI ISOLANTI RICAMBIO COMPATTE	COMP.SET OF INSULATING MAT.WALL-HUNG BOIL.
59	6CAMCORC00	1	CAMERA DI COMBUSTIONE RICAMBIO COMPATTA	COMBUSTION CHAMBER FOR WALL-HUNG BOILERS
60	6YTUBCON02	3m	TUBO IN SILICONE DIAMETRO INT. 4, ESTERNO 8	SILICONE PIPE: INSIDE Ø 4 MM, OUTSIDE Ø 8 MM
61	6BOLLITO09	1	BOLLITORE 25 LITRI	25 LITRES BOILER
62	6VALVSFI02	5	VALVOLA SFOGO 1/2"	1/2" RELIEF VALVE
63	6VASOESP16	1	VASO D'ESPANSIONE 2 LT	2 LITRE EXPANSION TANK
64	6VASOESP17	1	VASO D'ESPANSIONE 8 LT 24KW	8 LITRE EXPANSION TANK 24 KW
	6VASOESP15	1	VASO D'ESPANSIONE 10 LT 28-32KW	10 LITRE EXPANSION TANK 28-32 KW
65	6TUBFLEX05	1	TUBO FLESSIBILE	HOSE PIPE
66	6TUBFLEX02	1	TUBO FLESSIBILE F 3/8"X M10X1 X 450	HOSE PIPE F 3/8"X M10X1 X 450
67	6STRUPOR00	1	STRUTTURA PORTANTE CALDAIA	BOILER SUPPORTING STRUCTURE
68	6PANFRM00	1	PANNELLO ANTERIORE CALDAIA MURALE	WALL-HUNG BOILER FRONT PANEL
69	6PANLACM01	1	PANNELLO LATERALE	SIDE PANEL
70	6FONDMUR04	1	FONDELLO	BASE
71	6PIASFIS01	1	PIASTRA FISSAGGIO BOLLITORE	TANK HEATER CLAMP
72	6FRONCAM00	1	PANNELLO FRONTALE DELLA CAMERA COMBUSTIONE	COMBUSTION CHAMBER FRONT PANEL
73	6POSTCAM00	1	PANNELLO POSTERIORE DELLA CAMERA COMBUSTIONE	COMBUSTION CHAMBER REAR PANEL
74	6STASOST04	1	STAFFA DI AGGANCIO PER SOSTEGNO A MURO	HOOKING WALL BRACKET
75	6PROFPOR00	2	PROFILO PORTANTE CALDAIA	BOILER SUPPORTING PROFILE
76	6CURFIVG00	1	CURVETTA DI FISSAGGIO X VALVOLA SIT	ELBOW FOR SIT GAS VALVE
77	6VALVGAS03	1	VALVOLA GAS SIT SIGMA 845	GAS VALVE SIT SIGMA 845
78	6TUBOGAS11	1	TUBO GAS	GAS TUBE
79	6CANDELA00	3	CANDELETTA D'ACCENSIONE COMPATTA DUAL	SPARK PLUG FOR DUAL

80	6BRUMMET03	1	BRUCIATORE 12 RAMPE METANO 24KW	COMPLETE BURNER, 12 RAMPS, METHANE 24 KW
	6BRUMMET04	1	BRUCIATORE 13 RAMPE METANO 28KW	COMPLETE BURNER, 13 RAMPS, METHANE 28 KW
	6BRUMMET05	1	BRUCIATORE 15 RAMPE METANO 32KW	COMPLETE BURNER, 15 RAMPS, METHANE 32 KW
	6BRUMGPL03	1	BRUCIATORE 12 RAMPE G.P.L. 24KW	COMPLETE BURNER, 12 RAMPS, PLG 24 KW
	6BRUMGPL04	1	BRUCIATORE 13 RAMPE G.P.L. 28KW	COMPLETE BURNER, 13 RAMPS, PLG 28 KW
	6BRUMGPL05	1	BRUCIATORE 15 RAMPE G.P.L. 32KW	COMPLETE BURNER, 15 RAMPS, PLG 32 KW
	0TRASGPL03	12	TRASFORMAZIONE A G.P.L. DUAL 24	PLG CONVERSION KIT FOR 24 DUAL
	0TRASGPL06	13	TRASFORMAZIONE A G.P.L. DUAL 28	PLG CONVERSION KIT FOR 28 DUAL
	0TRASGPL07	15	TRASFORMAZIONE A G.P.L. DUAL 32	PLG CONVERSION KIT FOR 32 DUAL
	0TRASMET04	12	TRASFORMAZIONE A METANO DUAL 24	METHANE CONVERSION KIT FOR 24 DUAL
0TRASMET05	13	TRASFORMAZIONE A METANO DUAL 28 - DUAL RUS 24	METHANE CONVERSION KIT FOR 28 DUAL - 24 DUAL RUS	
0TRASMET07	15	TRASFORMAZIONE A METANO DUAL 32	METHANE CONVERSION KIT FOR 32 DUAL	
81	6STASUBR00	2	STAFFA DI SUPPORTO BRUCIATORE	BURNER BRACKET
82	6YTRAACC00	1	TRASFORMATORE DI ACCENSIONE	IGNITION TRANSFORMER
83	6GUAVAGA01	1	GUARNIZIONE PER VALVOLA GAS	GASKET FOR SIT GAS VALVE
84	6TAPPOGF04	1	TAPPO G 1/8" M	1/8" M PLUG
85	6CAVOALI00	1	CAVO DI ALIMENTAZIONE	SUPPLY CABLE
86	6CABLMUR22	1	CABLAGGIO 22	CONNECTOR 22
87	6CABLMUR23	1	CABLAGGIO 23	CONNECTOR 23
88	6SONDNTC02	1	SONDA NTC	NTC IMMERSION PROBE
89	6INTERRU02	1	INTERRUTTORE	SWITCH
90	6CABLMUR07	1	COLLEGAMENTO DUAL 7	CONNECTOR DUAL 7
91	6DIAFSCA01	3	DIAFRAMMA SCARICO FUMI 42MM	FLUE GAS DISCHARGE DIAPHRAGM Ø 42
	6DIAFSCA02	3	DIAFRAMMA SCARICO FUMI 45MM	FLUE GAS DISCHARGE DIAPHRAGM Ø 45
	6DIAFSCA04	3	DIAFRAMMA SCARICO FUMI 40MM	FLUE GAS DISCHARGE DIAPHRAGM Ø 40
	6DIAFSCA05	3	DIAFRAMMA SCARICO FUMI 49MM	FLUE GAS DISCHARGE DIAPHRAGM Ø 49
	6DIAFSCA07	3	DIAFRAMMA SCARICO FUMI 47MM	FLUE GAS DISCHARGE DIAPHRAGM Ø 47
	6DIAFSCA08	3	DIAFRAMMA SCARICO FUMI 51MM	FLUE GAS DISCHARGE DIAPHRAGM Ø 51
92	6CABLMUR24	1	CABLAGGIO 24	CONNECTOR 24
93	6SCHEMOD07	1	SCHEDA DI MODULAZIONE	MODULATION BOARD
94	6CIRCSTA08	1	SCHEDA RELE' PER GESTIONE ACQUA PREMIUM	RELAY PCB FOR AQUA PREMIUM MANAGEMENT
95	6WVETISP00	5	GUARNIZIONE IN SILICONE CON VETRINO D49MM	SILICONE GASKET WITH GLASS D49MM
96	6BYPRIDU00	1	BY-PASS RICAMBIO DUAL	SPARE BY-PASS PIPE FOR DUAL
97	6SCAELPP00	1	SCATOLA ELETTRONICA CALDAIA MURALE	BOX FOR ELECTRONIC COMPONENT PARTS
98	6ORINNMA00	10	O-RING DI TENUTA INNESTO MANOMETRO	PRESSURE GAUGE O-RING SEAL
99	6DADOZIG00	10	DADO ZIGRINATO	KNURLED NUT
100	6MANOMET01	1	MANOMETRO	PRESSURE GAUGE
101	6FRONBAS02	1	FRONTALE BASCULANTE PER PANNELLO	PANEL TILTING FRONT
102	6PARASIL00	10	PARACOLPI IN SILICONE	SILICONE BUFFER
103	6MAGNPER00	1	MAGNETE PERMANENTE COPPIA	PERMANENT MAGNET (PAIR)
104	6MANOBIA00	5	MANOPOLA D.18	KNOB Ø18 FOR BOILER INSTRUMENT PANELS
105	6FRONPAN03	1	PANNELLO PORTA-STRUMENTI PER CALDAIA MURALE	SERIGRAPHED INSTRUMENT PANEL WALL-HUNG BOLL.
106	6GUIPPCM00	3	GUIDALUCE PER PANNELLO PORTA-STRUMENTI	BOILER CONTROL PANEL LIGHT GUIDE
107	6YBOBINA00	1	BOBINA VALVOLA SIT 840-845-848	840-845-848 SIT GAS VALVE COIL
108	6CABLMUR25	1	CABLAGGIO 25	CONNECTOR 25
109	6GUARBOL02	1	GUARNIZIONE 8 FORI D.186	GASKET
110	6DADOBOL00	8	DADO ESAGONALE + VITE BOLLITORE	NUT + SCREW

111	6ANODMGN01	1	ANODO DI MAGNESIO	SACRIFICAL ANOD (MAGNESIUM)
112	6BLOCFLA00	1	BLOCCO FLANGIA BOLLITORE	FLANGE ASSEMBLY

